



# SINO TEST

## 中机试验

试验机夹具及附件

中国高端试验装备技术引领者

## Contents

Introduction: Grips and Fixtures .....	1
Coaxiality / Alignment Adjustment Ring .....	2
Grip Adapter .....	3
External Hanging Sensor Assembly .....	3
Mechanical Lever Action Grip .....	3
Rotating Wedge Grip .....	5
Hydraulic Wedge Grip .....	7
High and Low Temperature Hydraulic Grips .....	9
Hydraulic Side Action Tensile Grip .....	11
Pneumatic Wedge Grip .....	13
Pneumatic Side Action Tensile Grip .....	15
One-way Pneumatic Side Action Tensile Grip .....	16
5KN One-way Pneumatic Side Action Tensile Grip .....	17
Compression Platen .....	18
Bending Fixture .....	20
High Temperature Pull Rod Fixture .....	21
Shoulder Tensile Fixture .....	23
Shearing Fixture .....	24
Vise Grip .....	25
20N Vise Grip .....	30
Geotextile Grip .....	31
High and Low Temperature Vise Fixture .....	32
Scissor Action Grip .....	33
Hydraulic One-way Side Action Fixture .....	34
Fastener Tensile Fixture .....	35
Wire and Cable Tensile Grips .....	36
Webbing Tensile Grips .....	37
IITRI Compression Load Test Fixture .....	38
Combined Loading Compression (CLC) Fixture .....	39
Beam Bending and Shear Test Fixture .....	40
Three Point Bending Fixture .....	41

Three Point/ Four Point Bending Fixture .....	42
Short Beam Bending Fixture .....	43
Fastener Bearing Strength Test Fixtures .....	43
Open-Hole Compression Fixture .....	44
Sandwich Core Compression and Shear Fixture .....	44
Sandwich Core Tensile and Shear Fixture .....	45
Climbing Drum Peel Test Fixture .....	46
Mixed-Mode Bending Fracture Toughness Test Fixture .....	46
Roller Drum Peel Test Fixture .....	47
Glass Fiber Special Shearing Fixture .....	47
V-Notched Rail Shear Test Fixture .....	48
Mode I Interlaminar Fracture Toughness Test Fixture .....	48
Integrated HPU .....	49
Gas Station .....	50
Environmental Chamber .....	51
Atmospheric Furnace .....	53
CBY Axial Extensometer .....	54
Large Deformation Extensometer .....	55
MF High Temperature Extensometer .....	56
Reliant Axial Extensometer .....	57
Reliant Lateral (Radial) Extensometer .....	59
Reliant Deflectometer .....	61
Reliant High Temperature Axial Extensometer .....	63
Epsilon Axial Extensometer .....	65
Epsilon Lateral (Radial) Extensometer .....	66
Epsilon Deflectometer .....	67
Epsilon High Temperature Axial Extensometer .....	68
Fully Automatic Extensometer .....	69
MF Fully Automatic Extensometer .....	71
Video Extensometer .....	73
Grating Sensor .....	74

## Introduction: Grips and Fixtures

### Application of Grips and Fixtures

Grips and fixtures are key components for material testing. If you use the wrong grips and fixtures, it may affect the test results. SINOTEST provides various grips and fixtures. This catalog includes common products that are compatible with samples defined by commonly used testing standards (such as ASTM, ISO, DN, GB, BS, JIS, GOST, etc.).

### Product Compatibility

The grips and fixtures listed in this manual can be directly used for DF series UTM. If there are special requirements, you will need grip adapters to achieve your targets.

### Selection of Grips and Fixtures

Selecting grips and fixtures are very complex, but the main focus is on the following three aspects:

#### 1. Test load

It is recommended that the grips be subjected to a force greater than 1.25 times the expected maximum test load, which means that the grips can be operated at 80% of its capacity. The capacity of the load cell should match that of the grip (i.e. a 50 kN grip should use a load cell with a rated value of 50 kN). This can effectively ensure the accuracy of the results and a long-lasting service life.

#### 2. Test standard

Test standards define sample size and shape. Usually, various grips & fixtures can be selected. If you are unsure, please provide specific test standard code.

#### 3. Specimen and test method

Except sample size and shape, surface texture is also an important factor to consider when selecting fixtures. In a tensile test, improper grip selection often leads to fixture sliding, premature damage, and rupture. To help determine the correct fixture, please send us sample details and test methods.



**SINOTEST EQUIPMENT CO., LTD.**

[www.ccss.com.cn](http://www.ccss.com.cn)

<https://www.camcjsw-testmachines.com/>

## Coaxiality / Alignment Adjustment Ring

The alignment device produced by SINOTEST is used to collect, analyze and display bending strain, in order to calibrate and verify it. Through its graphical interface, you can quickly calibrate the system or verify the current bending strain. A key feature of this software is its ability to separate the bending strain of the sample from the bending strain of the load system.

The best method to determine bending strain is to use strain gauge samples. This product is directly connected to the strain gauge sample and displays the bending strain graphically on your computer screen. By continuously scanning the bending strain, you can calibrate the system or verify the bending strain during cyclic loading. After completion, you can generate an Excel report to authenticate your system.



### Features

1. Data collection and adjustment are performed outside the computer. This can greatly improve the flexibility of the computer;
2. This calibration system ensures compliance with the following industry standards: JB/T9397-2013;
3. It can guide users to perform alignment and angle adjustments through the "Calibration Guide" prompt;
4. It can receive calibration load signals and generate inspection charts for the relationship between bending percentage and bending strain with load;
5. It can peel off the specimen eccentricity from the system calibration.

Model	Rated load	Temp.	Size(H*OD)	Weight
DZH-204	20kN	RT	75mm×90mm	5kg
DZH-504	50kN	RT	76mm×95mm	5kg
DZH-105	100kN	RT	86mm×110mm	5kg
DZH-305	300kN	RT	111mm×145mm	11kg

## Grip Adapter

The grip adapter produced by SINOTEST serves as a bridge between the grip and the host, enabling clamps of different capacity to be connected to the same host, greatly enhancing the wide applicability of the clamps.

**Note: Grip adapters can be made according to actual needs**



## External Hanging Sensor Assembly

External-hanging sensor assembly can meet the requirements of conducting tests on hosts with different load that exceed the measurement range.

The external-hanging sensor assembly produced by SINOTEST has a simple structure, easy to install, and can meet the requirements of some small load tests. It uses Celtron STC sensors, with accurate and reliable measurement data.

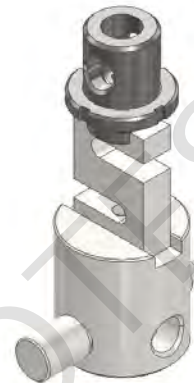

## Features

1. It can do the test that exceed the load accuracy;
2. It is easy to install, you only need to hang the sensor assembly on the host through a threaded pin;
3. It uses Celtron sensor, with precise force values.

## Suitable for 20kN machine and smaller ones

Model	Rated load	H*L*W (mm)
STC-102-252	250N	158×44×52

## Suitable for 200/300kN machine

Model	Rated load	H*L*W (mm)
STC-305-252	250N	215×65×65
STC-305-502	500N	215×65×65
STC-305-752	750N	215×65×65
STC-305-103	1kN	225×65×65
STC-305-253	2.5kN	240×70×70
STC-305-503	5kN	240×70×70

## Suitable for 50kN/100kN machine

Model	Rated load	H*L*W (mm)
STC-105-252	250N	175×44×52
STC-105-502	500N	175×44×52
STC-105-752	750N	175×44×52
STC-105-103	1kN	185×44×52
STC-105-253	2.5kN	200×70×70

## Suitable for 500/600kN machine

Model	Rated load	H*L*W (mm)
STC-605-252	250N	265×140×140
STC-605-502	500N	265×140×140
STC-605-752	750N	265×140×140
STC-605-103	1kN	275×140×140
STC-605-253	2.5kN	275×140×140
STC-605-503	5kN	275×140×140
STC-605-753	7.5kN	275×140×140



## Grips

There are usually 4 types of interfaces between the grips and the corresponding host, which are:  $\phi 20\text{mm}$ ,  $\phi 40\text{mm}$ ,  $\phi 65\text{mm}$  and  $\phi 95\text{mm}$ , the corresponding maximum test force values are 20kN, 100kN, 300kN, and 600kN.

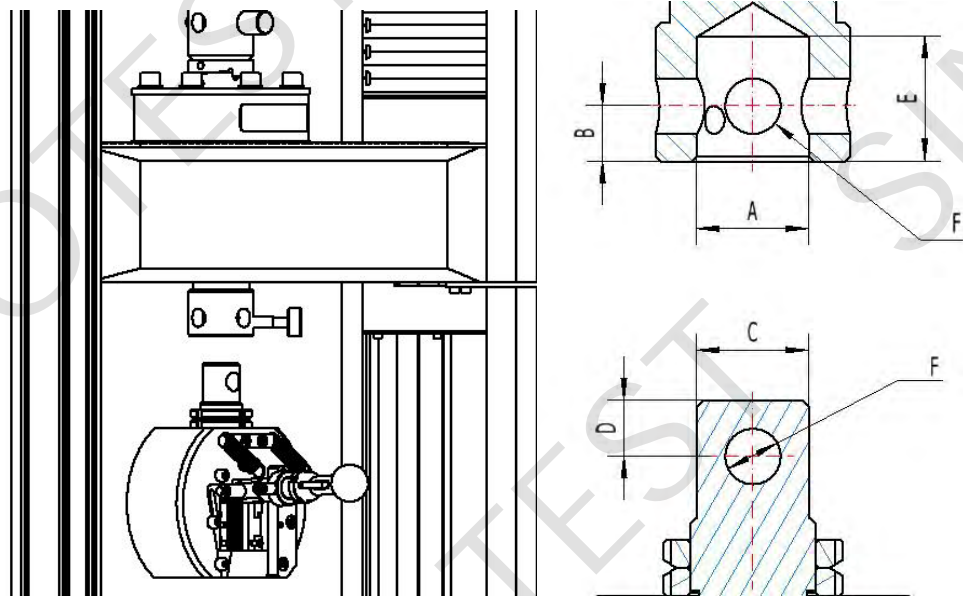

Load	Frame	A	B	C	D	E	F
20kN	5、10、20kN	$\phi 20\text{mm}$	12mm	$\phi 20\text{mm}$	12mm	30mm	$\phi 10\text{mm}$
100kN	50、100kN	$\phi 40\text{mm}$	20mm	$\phi 40\text{mm}$	20mm	45mm	$\phi 20\text{mm}$
300kN	200、300kN	$\phi 65\text{mm}$	35mm	$\phi 65\text{mm}$	35mm	75mm	$\phi 30\text{mm}$
600kN	500、600kN	$\phi 95\text{mm}$	49mm	$\phi 95\text{mm}$	49mm	100mm	$\phi 40\text{mm}$



## Mechanical Lever Action Grip

The mechanical lever action grip produced by SINOTEST is operated manually, which is simple, convenient, and cost-effective. The clamping force increases with the increase of the test force. The grips adopt a wedge-shaped handle type structure, which allows single hand operation to achieve loosening and clamping action. The operation is convenient and the clamping range is wide. The replacement of clamping blocks is very convenient. You can adjust the clamping force manually.



### Standards

GB/T 228.1-2021	<i>Metallic materials -- Tensile testing -- Part 1: Method of test at room temperature.</i>
ASTM E8-2016a	<i>Standard Test Methods For Tension Testing Of Metallic Materials.</i>
ISO 6892-1-2016	<i>Metallic materials -- Tensile testing -- Part 1: Method of test at room temperature.</i>
BS EN 10002-1	<i>Metallic materials - Tensile testing. Method of test at ambient temperature.</i>
JIS Z 2241-2011	<i>Metallic materials -- Tensile testing -- Method of test at room temperature.</i>

### Features

1. It only needs one handed operation which can improve clamping efficiency;
2. It is suitable for clamping soft metals ( $\leq 35\text{HRC}$ ), plastics, composite materials, and other materials;
3. The clamping force increases with the increase of tensile force on the specimen to prevent slipping;
4. The separation design between the clamp block and the clamp body enables quick replacement of the blocks, saving your time and effort.

### Grip specification

Model	Rated load	Flat block	File cut block(optional)	V block	Temp.	Size(H*W*D) (mm)	Weight /piece
JJ.001-504	50kN	0~24mm	0~9mm	$\phi 6 \sim \phi 34\text{mm}$	RT	230×195×100	20kg
JJ.001-105	100kN	0~24mm	0~9mm	$\phi 6 \sim \phi 34\text{mm}$	RT	230×195×100	20kg
JJ.001-205	200kN	0~28mm	0~12mm	$\phi 6 \sim \phi 30\text{mm}$	RT	316×295×142	40kg
JJ.001-305	300kN	0~28mm	0~12mm	$\phi 6 \sim \phi 30\text{mm}$	RT	316×295×142	40kg

**Clamp block specification**

Grip	Flat (mm)	File cut (mm) (optional)	V type (mm)
JJ.001-504	0~12、12~24	0~9	φ5.5~φ14.5、φ14.5~φ25.5、φ25.5~φ34.5
JJ.001-105	0~12、12~24	0~9	φ5.5~φ14.5、φ14.5~φ25.5、φ25.5~φ34.5
JJ.001-205	0~16、12~24、16~28	0~12	φ6~φ12、φ10~φ22、φ20~φ30
JJ.001-305	0~16、12~24、16~28	0~12	φ6~φ12、φ10~φ22、φ20~φ30

## Rotating Wedge Grip

The manual rotating wedge grip produced by SINOTEST is a widely used universal fixture that manually operated. Its clamping surface remains stationary during loading, making it particularly suitable for use when pneumatic and hydraulic grips cannot provide sufficient clamping force. Its clamping surface remains stationary during loading, making it convenient to replace clamping blocks.



### Standards

GB/T 228.1-2021	<i>Metallic materials -- Tensile testing -- Part 1: Method of test at room temperature</i>
ASTM E8-2016a	<i>Standard Test Methods For Tension Testing Of Metallic Materials</i>
ISO 6892-1-2016	<i>Metallic materials -- Tensile testing -- Part 1: Method of test at room temperature.</i>
BS EN 10002-1	<i>Metallic materials - Tensile testing. Method of test at ambient temperature.</i>
JIS Z 2241-2011	<i>Metallic materials -- Tensile testing -- Method of test at room temperature.</i>

### Features

1. Manual operation (rotation) for easy maintenance;
2. Reliable clamping without slipping;
3. It can provide high clamping force;
4. The clamping force increases with the increase of tensile force on the specimen to prevent slipping.

### Grip specification

Model	Rated load	Flat block	File cut block (optional)	V block	Temp.	Size(H*W*D)(mm)	Weight/pcs
JJ.002-104	10kN	0~9mm	0~6mm	φ5~φ12mm	RT	256×255×75	18kg
JJ.002-204	20kN	0~9mm	0~6mm	φ5~φ12mm	RT	256×255×75	18kg
JJ.002-504	50kN	0~12mm	0~9mm	φ6~φ25mm	RT	278×316×124	28kg
JJ.002-105	100kN	0~12mm	0~9mm	φ6~φ25mm	RT	278×316×124	28kg
JJ.002-205	200kN	0~16mm	0~12mm	φ8~φ28mm	RT	377×230×230	45kg
JJ.002-305	300kN	0~16mm	0~12mm	φ8~φ28mm	RT	377×230×230	45kg

### Clamp block specification

Grip	Flat block (mm)	File cut block (mm) (optional)	V block (mm)
JJ.002-104	0~9	0~6	φ5~φ12
JJ.002-204	0~9	0~6	φ5~φ12
JJ.002-504	0~12	0~9	φ6~φ14、φ14~φ25
JJ.002-105	0~12	0~9	φ6~φ14、φ14~φ25
JJ.002-205	0~16	0~12	φ8~φ16、φ14~φ22、φ20~φ28
JJ.002-305	0~16	0~12	φ8~φ16、φ14~φ22、φ20~φ28

## Hydraulic Wedge Grip

The hydraulic wedge grip produced by SINOTEST is a commonly used fixture for tension and compression, which is widely used in various models. Its clamping blocks are mainly divided into DL and DY forms, namely the inverted and straight stabbing types.



The hydraulic wedge grip uses a hydraulic power unit to clamp and release the specimen. During the clamping process, the clamping block itself moves horizontally, and the initial axial additional force on the specimen is very small.

### Standards

GB/T 228.1-2021	<i>Metallic materials -- Tensile testing -- Part 1: Method of test at room temperature</i>
ASTM E8-2016a	<i>Standard Test Methods For Tension Testing Of Metallic Materials</i>
ISO 6892-1-2016	<i>Metallic materials -- Tensile testing -- Part 1: Method of test at room temperature.</i>
BS EN 10002-1	<i>Metallic materials - Tensile testing. Method of test at ambient temperature.</i>
JIS Z 2241-2011	<i>Metallic materials -- Tensile testing -- Method of test at room temperature.</i>

### Features

1. You can push button to realize clamping and unclamping, which can improve clamping efficiency;
2. The clamping block is clamped in translation and the axial additional force is small;
3. The initial clamping force is adjustable (adjusted through the HPU);
4. It has large clamping force, suitable for hard test samples such as metal and non-metal materials.

### Grip specification

Model	Rated load	Flat block	File cut block(optional)	V block	Temp.	Size( $\phi$ D*H)(mm)	Weight/pcs
JJ.003-504	50kN	0~24mm	0~20mm	$\phi$ 6~ $\phi$ 34mm	RT	$\phi$ 200×190	40kg
JJ.003-105	100kN	0~24mm	0~20mm	$\phi$ 6~ $\phi$ 34mm	RT	$\phi$ 200×190	40kg
JJ.003-205	200kN	0~30mm	0~26mm	$\phi$ 6~ $\phi$ 40mm	RT	$\phi$ 256×227	85kg
JJ.003-305	300kN	0~30mm	0~26mm	$\phi$ 6~ $\phi$ 40mm	RT	$\phi$ 256×227	85kg

JJ.003-505	500kN	0~28mm	0~24mm	φ10~φ50mm	RT	φ320×292	160kg
JJ.003-605	600kN	0~28mm	0~24mm	φ10~φ50mm	RT	φ320×292	160kg

### Clamp block specification

Grip	Flat block (mm)	File cut block	V block (mm)
		(mm) (optional)	
JJ.003-504	0~12、12~24	0~20	φ6~φ14、φ14~φ25、φ25~φ34
JJ.003-105	0~12、12~24	0~20	φ6~φ14、φ14~φ25、φ25~φ34
JJ.003-205	0~14、12~24、18~30	0~26	φ6~φ12、φ10~φ22、φ20~φ30、φ30~φ40
JJ.003-305	0~14、12~24、18~30	0~26	φ6~φ12、φ10~φ22、φ20~φ30、φ30~φ40
JJ.003-505	0~12、12~23、23~34	0~24	φ10~φ18、φ18~φ26、φ26~φ34、φ34~φ42、φ42~φ50
JJ.003-605	0~12、12~23、23~34	0~24	φ10~φ18、φ18~φ26、φ26~φ34、φ34~φ42、φ42~φ50

## High and Low Temperature Hydraulic Grips

The high and low temperature hydraulic grips produced by SINOTEST has an external cylinder and a built-in jaw. It has a double water-cooled mechanism to prevent the clamp block and hydraulic oil from overheating. It can work stably in high temperature environment.



### Standards

GB/T 228.2-2015

*Metallic materials - Tensile testing - Part 2: Method of test at elevated temperature*

ASTM E21-2020

*Standard Test Methods for Elevated Temperature Tension Tests of Metallic Materials*

ISO 6892-2-2018

*Metallic materials - Tensile testing - Part 2: Method of test at elevated temperature*

### Features

1. Hydraulic clamping (automatic), large initial clamping force;
2. Reliable clamping without slipping;
3. The initial clamping force is adjustable (adjusted through the HPU);
4. Large clamping force, suitable for clamping hard specimens.

### Grip specification

Model	Rated load	Flat block	V block	Temp.	Weight
JJ.005-504	50kN	0~10mm	φ6~φ12mm	-70~350°C	140kg
JJ.005-105	100kN	0~10mm	φ6~φ12mm	-70~350°C	140kg
JJ.005-205	200kN	0~30mm	φ6~φ40mm	-70~350°C	290kg
JJ.005-305	300kN	0~30mm	φ6~φ40mm	-70~350°C	290kg



## Clamp block specification

Grip	Flat block (mm)	V block (mm)
JJ.005-504	0~5、5~10	φ6~φ12
JJ.005-105	0~5、5~10	φ6~φ12
JJ.005-205	0~14、12~24、18~30	φ6~φ12、φ10~φ22、φ20~φ30、φ30~φ40
JJ.005-305	0~14、12~24、18~30	φ6~φ12、φ10~φ22、φ20~φ30、φ30~φ40

### Note:

1. The size of high and low temperature hydraulic grips need to be determined according to the actual situation.
2. High and low temperature hydraulic grips need to be equipped with water circulation devices.

## KL-010A Cooling Device

### Features

1. Small size, easy to move and install;
2. It adopts fully automatic intelligent digital control, which is easy to operate and has intuitive fault display; the circulating water system adopts good-quality water pumps, polyethylene water tanks, polyethylene and PVC connecting materials, which are not easy to corrode and have a long service life;
3. The equipment is equipped with many alarms such as under-flow and over-high and low water temperature protection to protect the normal operation of user equipment and water coolers;

### Parameters

Model	KL-010A
Heat output	50W/°C
power supply	AC 1P~220V/50Hz
Working current	1A
Water pump power	24W
Rated head	8M
Rated flow	9L/min
Water tank storage capacity	3L



## Hydraulic Side Action Tensile Grip

The hydraulic side action tensile grips produced by SINOTEST can provide sufficient and constant clamping force, which can reduce the impact of other factors on test data, making it easier to obtain more accurate test data. The grips uses an HPU to clamp and release the specimen. The clamping block itself moves horizontally during the clamping process. Compared with traditional wedge grips, the clamping force does not change with the test force, making the clamping more reliable.

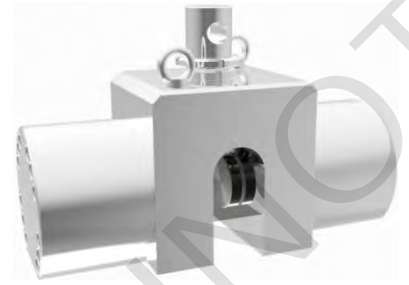

### Standards

GB/T 228.1-2021	<i>Metallic materials -- Tensile testing -- Part 1: Method of test at room temperature</i>
ASTM E8-2016a	<i>Standard Test Methods For Tension Testing Of Metallic Materials</i>
ISO 6892-1-2016	<i>Metallic materials -- Tensile testing -- Part 1: Method of test at room temperature.</i>
BS EN 10002-1	<i>Metallic materials - Tensile testing. Method of test at ambient temperature.</i>
JIS Z 2241-2011	<i>Metallic materials -- Tensile testing -- Method of test at room temperature.</i>

### Features

1. Use button switch to realize clamping and unclamping, improving clamping efficiency;
2. The clamping block moves horizontally for clamping, and the axial additional force is small;
3. The initial clamping force is adjustable (adjusted by HPU);
4. Large clamping force, suitable for hard test pieces such as metal/non-metal materials;
5. When the sample breaks, the clamping force will not disappear and there will be no obvious vibration or sound.

### Grip specifications

Model	Rated load	Flat block	V block	Temp.	Size(H*W*D)(mm)	Weight/pcs
JJ.004-504	50kN	1~30mm	φ6~φ25mm	RT	257×408×150	60kg
JJ.004-105	100kN	1~30mm	φ6~φ25mm	RT	257×408×150	60kg
JJ.004-205	200kN	1~50mm	φ10~φ45mm	RT	332×530×252	180kg
JJ.004-305	300kN	1~50mm	φ10~φ45mm	RT	332×530×252	180kg

**Clamp block specifications**

Grip	Flat block (mm)	V block (mm)
JJ.005-504	1~30	$\phi 6 \sim \phi 14$ 、 $\phi 14 \sim \phi 25$
JJ.005-105	1~30	$\phi 6 \sim \phi 14$ 、 $\phi 14 \sim \phi 25$
JJ.005-205	1~50	$\phi 10 \sim \phi 20$ 、 $\phi 20 \sim \phi 45$
JJ.005-305	1~50	$\phi 10 \sim \phi 20$ 、 $\phi 20 \sim \phi 45$

## Pneumatic Wedge Grip

Pneumatic wedge grips produced by SINOTEST provide you with versatility and reliability not found in other pneumatic clamps. The symmetrical appearance design ensures uniform specimen load throughout the wedge-shaped surface.

The grip adopts a pneumatic wedge-shaped tensile grip. The air valve of the grip is built in the grip body. It has a compact structure and reliable performance. The clamping and releasing action can be done with one hand operation, which is easy to operate. It has a wide clamping range and is very convenient to replace the clamping block, and the clamping force can be adjusted manually.



### Standards

GB/T 228.1-2021	<i>Metallic materials -- Tensile testing -- Part 1: Method of test at room temperature</i>
ASTM E8-2016a	<i>Standard Test Methods For Tension Testing Of Metallic Materials</i>
ISO 6892-1-2016	<i>Metallic materials -- Tensile testing -- Part 1: Method of test at room temperature.</i>
BS EN 10002-1	<i>Metallic materials - Tensile testing. Method of test at ambient temperature.</i>
JIS Z 2241-2011	<i>Metallic materials -- Tensile testing -- Method of test at room temperature.</i>

### Features

1. It can be operated by single finger, which has high clamping efficiency;
2. Suitable for clamping soft metal ( $\leq 35\text{HRC}$ ), plastic, composite materials, etc;
3. The clamping force increases as the tensile force on the sample increases to prevent slipping;
4. It uses clean energy and easy maintenance;
5. Single gas line, simple piping.

### Grip specification

Model	Rated load	Flat block	V block	Temp.	Size( $\phi$ D*H) (mm)	Weight/pcs
JJ.006-104	10kN	0~8mm	$\phi$ 6~ $\phi$ 11mm	RT	$\phi$ 172×231	20kg
JJ.006-204	20kN	0~8mm	$\phi$ 6~ $\phi$ 11mm	RT	$\phi$ 172×231	20kg
JJ.006-504	50kN	0~24mm	$\phi$ 6~ $\phi$ 34mm	RT	$\phi$ 210×268	40kg
JJ.006-105	100kN	0~24mm	$\phi$ 6~ $\phi$ 34mm	RT	$\phi$ 210×268	40kg
JJ.006-205	200kN	0~30mm	$\phi$ 6~ $\phi$ 40mm	RT	$\phi$ 266×340	80kg
JJ.006-305	300kN	0~30mm	$\phi$ 6~ $\phi$ 40mm	RT	$\phi$ 266×340	80kg

### Clamp block specification

Grip	Flat block (mm)	V block (mm)
JJ.006-104	0~8	$\phi$ 6~ $\phi$ 11
JJ.006-204	0~8	$\phi$ 6~ $\phi$ 11
JJ.006-504	0~12、12~24	$\phi$ 6~ $\phi$ 14、 $\phi$ 14~ $\phi$ 25、 $\phi$ 25~ $\phi$ 34
JJ.006-105	0~12、12~24	$\phi$ 6~ $\phi$ 14、 $\phi$ 14~ $\phi$ 25、 $\phi$ 25~ $\phi$ 34
JJ.006-205	0~14、14~24、18~30	$\phi$ 6~ $\phi$ 12、 $\phi$ 10~ $\phi$ 22、 $\phi$ 20~ $\phi$ 30、 $\phi$ 30~ $\phi$ 40
JJ.006-305	0~14、14~24、18~30	$\phi$ 6~ $\phi$ 12、 $\phi$ 10~ $\phi$ 22、 $\phi$ 20~ $\phi$ 30、 $\phi$ 30~ $\phi$ 40

## Pneumatic Side Action Tensile Grip

The pneumatic side action tensile grip produced by SINOTEST is a device used on material tensile testing machines to provide initial clamping force to the specimen. The additional axial force of the device is minimal and the is reliable to clamp the specimens.



### Standards

GB/T 228.1-2021	<i>Metallic materials -- Tensile testing -- Part 1: Method of test at room temperature</i>
ASTM E8-2016a	<i>Standard Test Methods For Tension Testing Of Metallic Materials</i>
ISO 6892-1-2016	<i>Metallic materials -- Tensile testing -- Part 1: Method of test at room temperature.</i>
BS EN 10002-1	<i>Metallic materials - Tensile testing. Method of test at ambient temperature.</i>
JIS Z 2241-2011	<i>Metallic materials -- Tensile testing -- Method of test at room temperature.</i>

### Features

1. Horizontal moving clamping with minimal axial additional force;
2. The initial clamping force is adjustable;
3. The clamping range is large and the clamping blocks do not need to be replaced frequently;
4. Suitable for non-metallic test samples such as film materials, cloths, rubber, etc.;
5. A variety of optional clamping blocks can be used according to the sample material;
6. Asymmetric samples can be clamped;
7. The clamping force can increase as the tensile force of the sample increases to avoid slipping.



### Grip specification

Model	Rated load	Flat block	Temp.	Size(H*W*D)(mm)	Weight/pcs
JJ.007-102	100N	0~7	RT	134×73×60	0.8kg
JJ.007-103	1kN	0~7	RT	163×83×70	1.5kg
JJ.007-203	2kN	0~7	RT	183×120×105	2.2kg
JJ.007-503	5kN	0~14	RT	193×158×140	3.5kg
JJ.007-104	10kN	0~14	RT	235×205×200	8.4kg
JJ.007-204	20kN	0~14	RT	256×238×220	15.8kg

## One-way Pneumatic Side Action Tensile Grip

The one-way pneumatic side action tensile grip produced by SINOTEST uses clean energy, has a simple structure, small mass, and easy maintenance. It can be manually aligned and clamp asymmetric specimens.

### Standards

GB/T 1040.3-2006 *Plastics - Determination of tensile properties -Part 3. Test conditions for films and sheets*

ASTM D1004-07 *Standard Test Method for Tear Resistance (Graves Tear) of Plastic Film and Sheeting*

ISO 527-3: 2003 *Plastics - Determination of tensile properties - Part 3: Test conditions for films and sheets*

QB/T 1130-1991 *Plastics Angle Tear Performance Test Method*



### Features

1. Horizontal moving clamping with minimal axial additional force;
2. The initial clamping force is adjustable;
3. The clamping range is large and the clamping blocks do not need to be replaced frequently;
4. Suitable for clamping test samples such as plastic film materials, metal foil layers, and rubber sheets;
5. Asymmetric samples can be clamped;

### Grip specification

Model	Rated load	Flat block	Temp.	Size(H*W*D)(mm)	Weight/pcs
JJ.008-102	100N	0~3	RT	120×85×55	0.4kg
JJ.008-502	500N	0~6	RT	150×105×70	0.9kg
JJ.008-103	1kN	0~4	RT	155×115×85	1.1kg



## 5KN One-way Pneumatic Side Action Tensile Grip

The 5KN one-way pneumatic side action tensile grip produced by SINOTEST uses clean energy, has a simple structure, small mass, and easy maintenance. It can be manually aligned and clamp asymmetric specimens.

### Feature

1. Horizontal moving clamping with minimal axial additional force;
2. The initial clamping force is adjustable;
3. Suitable for clamping test samples such as plastic films, metal foil layers, fabric fibers, etc;
4. Asymmetric samples can be clamped;



### Grip specification

Model	Rated load	Flat block	Temp.	Size(H*W*D)(mm)	Weight/pcs
JJ.008-503	5kN	0~6	RT	155×200×120	5kg

## Compression Platen

The compression platen produced by SINOTEST is very practical. It has a high-precision base and hardened surface. Available in a variety of sizes, these platens feature a universal connector design and optional threaded bracket connectors for easy mounting to electronic UTM and hydraulic UTM. Sample concentric rings, anti-rotation function and integrated positioning pins improve test accuracy and repeatability.

### Standards

GB/T 7314-2017 *Metallic materials -- Compression test method at room temperature*

### Features

1. It has sample concentric rings;
2. It can anti rotate and has integrated positioning pins;
3. The material of the compression platen can be adjusted according to the testing samples.



### Grip specification

#### Compression platen without spherical

Model	Rated load	Temp.	Diameter (mm)	Weight
JJ.010-104	10kN	RT	90	2kg
JJ.010-204	20kN	RT	90	2kg
JJ.010-504	50kN	RT	120	8kg
JJ.010-105	100kN	RT	120	8kg
JJ.010-205	200kN	RT	135	12kg
JJ.010-305	300kN	RT	135	12kg
JJ.010-505	500kN	RT	240	38kg
JJ.010-605	600kN	RT	240	38kg

### Compression platen with spherical

Model	Rated load	Temp.	Diameter (mm)	Weight
JJ.011-104	10kN	RT	90	2kg
JJ.011-204	20kN	RT	90	2kg
JJ.011-504	50kN	RT	120	8kg
JJ.011-105	100kN	RT	120	8kg
JJ.011-205	200kN	RT	135	12kg
JJ.011-305	300kN	RT	135	12kg
JJ.011-505	500kN	RT	240	38kg
JJ.011-605	600kN	RT	240	38kg

### Compression clamp with gauge base

Model	Rated load	Temp.	Diameter (mm)	Weight
JJ.013-104	10kN	RT	90	2kg
JJ.013-204	20kN	RT	90	2kg
JJ.013-504	50kN	RT	120	8kg
JJ.013-105	100kN	RT	120	8kg
JJ.013-205	200kN	RT	135	12kg
JJ.013-305	300kN	RT	135	12kg
JJ.013-505	500kN	RT	240	38kg
JJ.013-605	600kN	RT	240	38kg

*Note: This compression platen does not include dial indicator and grating ruler.*

### High and low temperature compression platen

Model	Rated load	Temp.	Diameter (mm)	Weight
JJ.014-204	20kN	-70~350°C	90	2kg
JJ.014-204	20kN	-70~350°C	90	2kg
JJ.014-105	100kN	-70~350°C	120	8kg
JJ.014-105	100kN	-70~350°C	120	8kg

*Note: The size of the compression platen can be customized according to customer requirements.*

## Bending Fixture

The bending fixture produced by SINOTEST is suitable for various tests. The span is adjustable and easy to use. The base is equipped with a ruler to make the positions of the left and right support rollers accurate. The high-hardness grinding roller can reduce unnecessary load and friction on the specimen to ensure accurate testing.



## Standards

GB/T 14452-1993 *Metallic Materials--Determination Of Bending Mechanical Properties*

GB/T 232-2010 *Metallic Materials - Bend Test*

## Features

1. High stiffness and stable performance;
2. The press roller can rotate, which can reduce errors caused by friction;
3. Good alignment, which is more conducive to the reliability of the test.



## Grip specification

Model	Rated load	Span	Width of the press roller	Temp.	Size(H*W*D)(mm)	Weight
JJ.015-104	10kN	20~140mm	50mm	RT	200×200×50	11kg
JJ.015-204	20kN	20~140mm	50mm	RT	200×200×50	11kg
JJ.015-504	50kN	36~320mm	80mm	RT	350×460×100	22kg
JJ.015-105	100kN	36~320mm	80mm	RT	350×460×100	22kg
JJ.015-205	200kN	30~320mm	90mm	RT	380×450×110	30kg
JJ.015-305	300kN	30~320mm	90mm	RT	380×450×110	30kg

## High Temperature Pull Rod Fixture

The high-temperature tensile fixture produced by SINOTEST is suitable for various high-temperature tensile tests. It contains multiple specifications and is easy to use. Different high-temperature materials are selected to meet different high-temperature test requirements and ensure test accuracy.

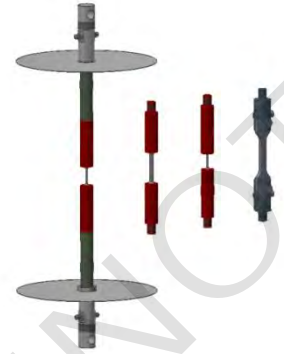

### Standards

GB/T 228.2-2015 *Metallic materials -- Tensile testing -- Part 2: Method of test at elevated temperature*

### Features

1. Stable performance in high temperature environment;
2. The installation and disassembly of the specimen is simple and convenient;
3. The structure is simple, which is more conducive to the reliability of the test.

### Grip specification

Model	Rated load	Material	Pin hole diameter	Connection thread	Temp.	Size( $\phi$ D*H)(mm)	Weight
JJ.023-504-K5	50kN	K465	$\phi$ 20mm	M20 $\times$ 2	200~900 $^{\circ}$ C	$\phi$ 325 $\times$ 800	11kg
JJ.023-105-K5	100kN	K465	$\phi$ 20mm	M20 $\times$ 2	200~900 $^{\circ}$ C	$\phi$ 325 $\times$ 800	11kg
JJ.023-205-K5	200kN	K465	$\phi$ 30mm	M30 $\times$ 2	200~900 $^{\circ}$ C	$\phi$ 325 $\times$ 850	22kg
JJ.023-305-K5	300kN	K465	$\phi$ 30mm	M30 $\times$ 2	200~900 $^{\circ}$ C	$\phi$ 325 $\times$ 850	22kg

Fixture	Round specimen connection thread	Flat specimen
JJ.023-504-K5	M10、M12、M16	1~8mm
JJ.023-105-K5	M10、M12、M16	1~8mm
JJ.023-205-K5	M10、M12、M16	1~10mm
JJ.023-305-K5	M10、M12、M16	1~10mm

Model	Rated load	Material	Pin hole diameter	Connection thread	Temp.	Size( $\phi$ D*H)(mm)	Weight
JJ.023-504-D2	50kN	DZ22	$\phi$ 20mm	M20×2	200~1050°C	$\phi$ 325×800	11kg
JJ.023-105-D2	100kN	DZ22	$\phi$ 20mm	M20×2	200~1050°C	$\phi$ 325×800	11kg
JJ.023-205-D2	200kN	DZ22	$\phi$ 30mm	M30×2	200~1050°C	$\phi$ 325×850	22kg
JJ.023-305-D2	300kN	DZ22	$\phi$ 30mm	M30×2	200~1050°C	$\phi$ 325×850	22kg

Fixture	Round specimen connection thread	Flat specimen
JJ.023-504-D2	M10、M12、M16	1~8mm
JJ.023-105-D2	M10、M12、M16	1~8mm
JJ.023-205-D2	M10、M12、M16	1~10mm
JJ.023-305-D2	M10、M12、M16	1~10mm

**Note:** During high-temperature tensile testing, a water cooler is required (see the accessories section of the manual).

## Shoulder Tensile Fixture

The shoulder tensile fixture produced by SINOTEST is used to clamp the specimen manually. It is mainly used in situations where the specimen length is small and the specimen clamping end is short. Compared with the threaded connection method, its installation is simple and convenient, and is also efficient in sample disassembly.



### Standards

GB/T 228.1-2021	<i>Metallic materials -- Tensile testing -- Part 1: Method of test at room temperature</i>
ASTM E8-2016a	<i>Standard Test Methods For Tension Testing Of Metallic Materials</i>
ISO 6892-1-2016	<i>Metallic materials -- Tensile testing -- Part 1: Method of test at room temperature.</i>
BS EN 10002-1	<i>Metallic materials - Tensile testing. Method of test at ambient temperature.</i>
JIS Z 2241-2011	<i>Metallic materials -- Tensile testing -- Method of test at room temperature.</i>

### Features

1. The sample installation process is simple and convenient;
2. It has reliable clamping without slipping;
3. Suitable for specimens with shorter clamping ends in tensile tests.

### Grip specification

Model	Rated load	Diameter	Temp.	Size( $\phi D * H$ )	Weight/pcs
JJ.029-305	300kN	$\phi 5$ 、 $\phi 10$ mm	RT	$\phi 98 \times 194$ mm	7kg

### Specimen requirement

The specimen should be round rod, as shown in the figure.

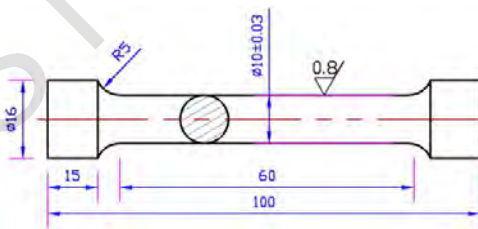

Fig 1.  $\phi 10$ mm round specimen

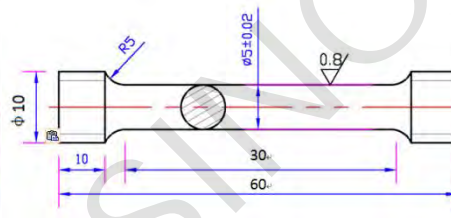

Fig 2.  $\phi 5$ mm round specimen

**Note:** Other specifications of fixtures can be customized according to customer needs.



## Shearing Fixture

The shearing fixture produced by SINOTEST has a simple structure and can be placed directly on the compression fixture for testing. It is easy to use and can quickly install and remove the specimen.

### Standards

GB/T 13683-1992 *Pins and grooved pins. Shear test*

ISO 8749-1986 *Pins and grooved pins. Shear test*

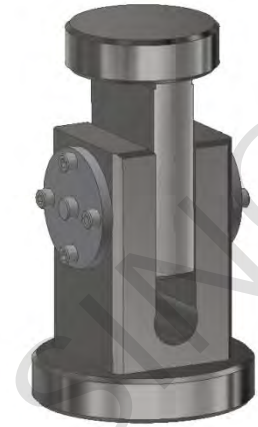

### Features

1. It has simple structure and is easy to install and disassemble;
2. Convenient to install the specimen;
3. Reliable clamping without slipping.

### Grip specification

Model	Rated load	Diameter	Temp.	Size( $\phi$ D*H)	Weight
JJ.019-105	100kN	$\phi$ 10mm	RT	$\phi$ 100×170mm	5kg

*Note: Other specifications of fixtures can be customized according to customer needs.*

## Vise Grip

The vise grip produced by SINOTEST is economical, and can be widely used. It can provide high-strength clamping force. It is especially suitable for use when pneumatic clamps and hydraulic clamps cannot provide sufficient clamping force. The clamping surface remains stationary during loading. The clamping block is easy to replace and can be used in conjunction with hydraulic UTM and electric UTM.



## Features

1. You can operate it manually. It is convenient for maintenance;
2. It has manual alignment can clamp asymmetric specimens;
3. Reliable clamping without slipping.

## Application

It is suitable for tensile testing of samples such as plastic films, aluminum sheets, and copper sheets.

## Standards

GB/T 1040.3-2006	<i>Plastics - Determination of tensile properties -Part 3. Test conditions for films and sheets</i>
ISO 527-3:2003	<i>Plastics - Determination of tensile properties -Part 3: Test conditions for films and sheets</i>
ASTM D882-10	<i>Standard Test Method for Tensile Properties of Thin Plastic Sheeting</i>

## Grip specification

Model	Rated load	Block width	Temp.	Max. Specimen thickness	Size(H*W*D)	Weight/pcs
JJ.024-102A	100N	32mm	RT	5mm	105×60×60mm	0.2kg
JJ.024-502A	500N	32mm	RT	5mm	105×60×60mm	0.6kg

## Application

It is suitable for tensile testing of metallic and non-metallic plates and wires.

## Standards

GB/T 1040.2-2006 *Plastic -Determination of tensile properties -Part 2: Test conditions for moulding and extrusion plastic*

GB/T 1040.3-2006 *Plastics -Determination of tensile properties -Part 3. Test conditions for films and sheets*

ISO 527-2:2012 *Plastics -Determination of tensile properties -Part 2: Test conditions for moulding and extrusion plastics*

ISO 527-3 : 2003 *Plastics -Determination of tensile properties -Part 3. Test conditions for films and sheets*

ASTM D882-08 *Standard Test Method for Tensile Properties of Thin Plastic Sheeting*

ASTM D882-10 *Standard Test Method for Tensile Properties of Thin Plastic Sheeting*



## Grip specification

Model	Rated load	Block width	Temp.	Max. Specimen thickness	Size(H*W*D)	Weight/pcs
JJ.024-103B	1kN	25mm	RT	12mm	110×110×40mm	0.9kg

Block specifications	
Plain block	0-12
Rubber coated block (optional)	0-12
Grip dotted block (optional)	0-12

### Application

Suitable for tensile testing of textile samples.

### Standards

GB/T 3923.2-2013 *Textiles -- Tensile properties of fabrics -- Part 2: Determination of maximum force using the grab method*

GB/T 13773-1992 *Woven Fabric And Its Products--Testing Method For Seam Strength And Seam Efficiency*



### Grip specification

Model	Rated load	Block size (mm)	Temp.	Max. Specimen thickness	Size(H*W*D)	Weight/pcs
JJ.024-303C	3kN	25×25、50×25	RT	14mm	154×143×50mm	2.5kg

### Application

Suitable for tensile testing of asphalt waterproofing membrane samples.

### Standards

GB/T 328.8-2007 *Test methods for building sheets for waterproofing -- Part 8: Bitumen sheets for waterproofing-tensile properties*



### Grip specification

Model	Rated load	Block type	Temp.	Max. Specimen thickness	Size(H*W*D)	Weight/pcs
JJ.024-303D	3kN	Serrated (Pyramid) blocks	RT	12mm	120×145×135mm	2kg
JJ.031-303D	3kN	Serrated (Pyramid) blocks	-40~120°C	12mm	120×145×135mm	2kg

### Application

Suitable for tensile testing of glass fiber mesh and other samples.

### Standards

GB/T 7689.5-2013

*Reinforcements -Test method for woven fabrics -Part 5: Determination of glass fibre tensile breaking force and elongation at break*

ISO 4606:1995

*Textile glass -Woven fabric -Determination of tensile breaking force and elongation at break by the strip method*



### Grip specification

Model	Rated load	Block type	Block width	Temp.	Max. Specimen thickness	Size(H*W*D)	Weight/pcs
JJ.024-503E	5kN	Rubber block	60mm	RT	10mm	120×110×90mm	2kg

### Application

Suitable for tensile testing of textile samples.

### Standards

GB/T 6759-2002

*Textile conveyor belts--Adhesive strength between constitutive elements--Test methods*



### Grip specification

Model	Rated load	Block type	Block width	Temp.	Max. Specimen thickness	Size(H*W*D)	Weight/pcs
JJ.024-503F	5kN	Serrated (Pyramid) blocks	80mm	RT	12mm	130×120×135mm	2.5kg

## Application

Suitable for tensile testing of metal and non-metal plates and bars.

## Standards

GB/T 228.1-2021 *Metallic materials -- Tensile testing -- Part 1: Method of test at room temperature*

ASTM E8-2016a *Standard Test Methods For Tension Testing Of Metallic Materials*

ISO 6892-1-2016 *Metallic materials -- Tensile testing -- Part 1: Method of test at room temperature.*

GB/T 1040.2-2006 *Plastic -Determination of tensile properties -Part 2: Test conditions for moulding and extrusion plastic*

ISO 527-2:2012 *Plastics -Determination of tensile properties -Part 2: Test conditions for moulding and extrusion plastics*

ASTM D882-08 *Standard Test Method for Tensile Properties of Thin Plastic Sheeting*



## Grip specification

Model	Rated load	Flat block	V block	Block width	Temp.	Size(H*W*D)	Weight/pcs
JJ.024-104G	10kN	0~20mm	φ4~φ14mm	40mm	RT	164×250×72mm	10kg

## 20N Vise Grip

### Application

It is suitable for tensile testing of filaments, thin wires and spandex yarns.

### Standards

GB/T 30311-2013 *Test method for tensile properties of dipped aramid yarns and cords*

GB/T 14344-2008 *Testing method for tensile of man-made filament yarns*

FZ/T 50006-2013 *Testing method for tenacity of spandex filament yarns*

FZ/T 50007-2012 *Testing method for elasticity of spandex filament yarns*



### Grip specification

Model	Rated load	Block width	Temp.	Max. Specimen thickness	Size(H*W*D)	Weight
JJ.024-201	20N	10mm	RT	φ0.2mm	250×86×40mm	1kg



## Geotextile Grip

The geotextile grip produced by SINOTEST adopts a double-side clamping method, which is simple in structure, and can provide greater clamping strength.

### Standards

GB/T 1040.3-2006 *Plastics - Determination of tensile properties -Part 3.*

*Test conditions for films and sheets*

GB/T 3917.2-2009 *Textile -- Tear properties of fabrics -- Part 2:*

*Determination of tear force of trouser-shaped test specimens (Single tear method)*

GB/T 7689.5-2013 *Reinforcements -- Test method for woven fabrics -- Part*

*5: Determination of glass fibre tensile breaking force and elongation at break*



### Features

1. Adopting double-side clamping method, which is convenient and reliable;
2. There are scales on the jaws for easy alignment;
3. Reliable clamping without slipping.

### Grip specification

Model	Rated load	Block type	Block width	Temp.	Max. Specimen thickness	Size(H*W*D)	Weight/pcs
JJ.024-204B	20kN	Serrated (Pyramid) blocks	210mm	RT	10mm	156×210×174m m	16kg

## High and Low Temperature Vise Fixture

The high and low temperature vise fixture produced by SINOTEST has a simple structure and is easy to operate. The alignment can be adjusted manually, and the process of installing and removing the sample is simple and convenient.

### Standards

GB/T 228.2-2015 *Metallic materials -- Tensile testing -- Part 2: Method of test at elevated temperature*

ASTM E21-2020 *Standard Test Methods for Elevated Temperature Tension Tests of Metallic Materials*

ISO 6892-2-2018 *Metallic materials - Tensile testing - Part 2: Method of test at elevated temperature*

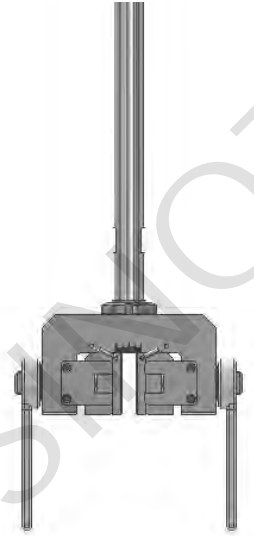

### Features

1. Adopting thread tightening clamping method, which is convenient and reliable;
2. There are scales engraved on the surface for easy alignment;
3. The clamping force is moderate, suitable for tensile testing of metal sheets and other specimens;
4. Reliable clamping without slipping.

### Grip specification

Model	Rated load	Flat block	Temp.	Size(H*W*D)	Weight/pcs
JJ.031-204	20kN	0~20mm	-70~350°C	150×180×50mm	4kg

## Scissor Action Grip

The scissor action grip produced by SINOTEST adopts a lever self-locking clamping method with simple structure and firm clamping.

### Standards

ISO 527-3:1995 *Plastics-Determination of tensile properties-Part 3: Test conditions for films and sheets*

ASTM D882-10 *Standard Test Method for Tensile Properties of Thin Plastic Sheeting*

GB/T 1040.3-2006 *Plastics - Determination of tensile properties -Part 3. Test conditions for films and sheets*

GB/T 528-2009 *Rubber, vulcanized or thermoplastic -- Determination of tensile stress-strain properties*



### Features

1. Adopting lever self-locking clamping method, the clamping is convenient and reliable;
2. The clamping force is moderate, suitable for tensile testing of rubber, plastic sheets and other samples;
3. Reliable clamping without slipping.

### Grip specification

Model	Rated load	Block width	Block type	Temp.	Max. Specimen thickness	Size(H*W*D)	Weight /pcs
JJ.030-203	2kN	40mm	Grip dotted block (optional)	RT	7mm	120×105×50mm	0.5kg
JJ.030-503	5kN	40mm	Grip dotted block (optional)	RT	12mm	160×150×75mm	1.5kg
JJ.032-203	2kN	40mm	Grip dotted block (optional)	-70~350°C	7mm	120×105×50mm	0.5kg
JJ.032-503	5kN	40mm	Grip dotted block (optional)	-70~350°C	12mm	160×150×75mm	1.5kg

## Hydraulic One-way Side Action Fixture

The hydraulic one-way side action fixture produced by SINOTEST can be adjusted and aligned manually and is able to clamp asymmetric specimens.

The fixture uses an HPU to clamp and release the specimen. The clamping block itself moves horizontally during the clamping process. Compared with traditional wedge clamps, the clamping force is more stable.

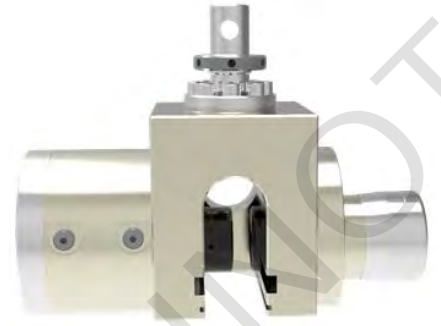

### Standards

GB/T 228.1-2021	<i>Metallic materials -- Tensile testing -- Part 1: Method of test at room temperature</i>
ASTM E8-2016a	<i>Standard Test Methods For Tension Testing Of Metallic Materials</i>
ISO 6892-1-2016	<i>Metallic materials -- Tensile testing -- Part 1: Method of test at room temperature.</i>
BS EN 10002-1	<i>Metallic materials - Tensile testing. Method of test at ambient temperature.</i>
JIS Z 2241-2011	<i>Metallic materials -- Tensile testing -- Method of test at room temperature.</i>

### Features

1. Horizontal moving clamping with minimal axial additional force;
2. The initial clamping force is adjustable;
3. Large clamping force, suitable for hard specimens such as metals;
4. The alignment can be adjusted manually and is able to clamp asymmetric specimens.

### Grip specification

Model	Rated load	Flat block	V block	Temp.	Size(H*W*D)	Weight/pcs
JJ.025-105	100kN	0~42mm	φ6~φ22mm	RT	305×396×188mm	90kg

## Fastener Tensile Fixture

The fastener tensile fixture produced by SINOTEST has a simple structure and has good coaxiality.

### Standards

GB/T 228.1-2021 *Metallic materials -- Tensile testing -- Part 1: Method of test at room temperature*

### Features

1. It has good alignment and is beneficial to the reliability of the test.
2. It can be operated manually and is easy to do maintenance
3. Reliable clamping without slipping.



### Grip specification

Model	Rated	Clamping Range	Temp.	Size( $\phi$ D*H)(mm)	Weight/pcs
JJ.026-105	100kN	M6~M10	RT	$\phi$ 88×175	10kg
JJ.026-205	200kN	M5~M18	RT	$\phi$ 98×203	15kg
JJ.026-305	300kN	M5~M18	RT	$\phi$ 98×203	15kg
JJ.026-505	500kN	M12~M22	RT	$\phi$ 150×250	38kg
JJ.026-605	600kN	M12~M24	RT	$\phi$ 150×250	38kg

### Clamp block specification

Grip model	Specification	4° wedge load	6° wedge load	10° wedge load
JJ.026-105	M5 <sup>1</sup> , M6 <sup>1</sup> , M8, M10	✓	✓	✓
JJ.026-205	M6 <sup>1</sup> , M8, M10, M12, M14	✓	✓	✓
JJ.026-305	M6 <sup>1</sup> , M8, M10, M12, M14, M16, M18	✓	✓	✓
JJ.026-505	M8, M10, M12, M16, M18, M20, M22	✓	✓	✓ <sup>2</sup>
JJ.026-605	M8, M10, M12, M16, M18, M20, M22, M24	✓	✓	✓ <sup>2</sup>

#### Notes:

1. M5 and M6 bolts need to be equipped with thread adapters and thread washers
2. M22 and above specifications do not support 10° wedge load test

## Wire and Cable Tensile Grips

The wire and cable tensile grips produced by SINOTEST is a special grip for cable specimens. It is manually operated, simple and convenient. It has a clamping device to make sure the tight clamping.

### Standards

GB/T 30311-2013 *Test method for tensile properties of dipped aramid yarns and cords*

GB/T 14344-2008 *Testing method for tensile of man-made filament yarns*



### Features

1. It can be operated manually and is easy to do maintenance
2. Suitable for clamping multi-diameter cable styles;
3. Reliable clamping without slipping.

### Grip specification

Model	Rated load	Max. Specimen diameter	Temp.	Size(H*W*D)(mm)	Weight/pcs
JJ.027-503	5kN	φ5mm	RT	130×140×60	4kg
JJ.027-104	10kN	φ6mm	RT	140×150×60	5kg
JJ.027-204	20kN	φ8mm	RT	154×162×85	5kg

## Webbing Tensile Grips

The webbing tensile grips produced by SINOTEST is a special fixture for webbing testing. It is simple to operate and can wrap specimens with different widths.

### Standards

GB 14166-93      *Safety-belts, restraint systems, child restraint systems and ISOFIX child restraint systems for occupants of power-driven vehicles*

QB/T 3811-1999      *Plastic packing belt*

### Features

1. It can be operated manually and is easy to do maintenance
2. Suitable for clamping multi-diameter webbing styles;
3. Suitable for tests on specimens like cloth tapes.
4. Reliable clamping without slipping.



### Grip specification

Model	Rated load	Temp.	Max. Specimen width	Max. Specimen thickness	Size(H*W*D)	Weight/pcs
JJ.028-204	20kN	RT	70mm	2mm	150×150×110mm	4kg
JJ.028-304	30kN	RT	70mm	5mm	166×172×120mm	5kg
JJ.028-105	100kN	RT	80mm	5mm	272×197×132mm	11kg



## Composite Material Mechanical Testing Grips and Fixtures

### IITRI Compression Load Test Fixture

This fixture is designed according to the dimensions of compression test specimens in ASTM D3410 and is a dedicated compression fixture for unidirectional fiber reinforced plastic flat plates. The fixture needs to be used with a standard  $\phi 150\text{mm}$  compression platen.

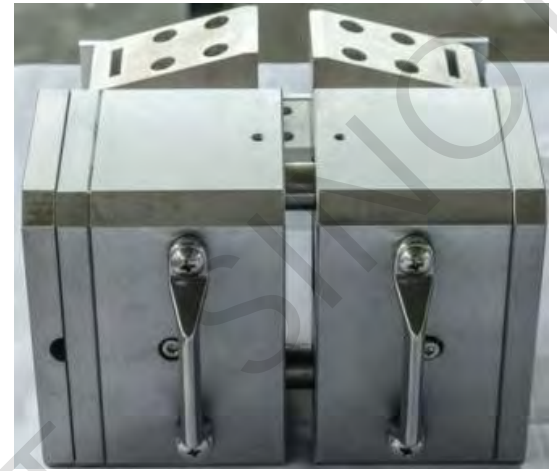

### Application

Specimen length: 140-155mm;

Min. gauge length: 10mm;

Max. gauge length: 25mm;

Specimen width: 10-25mm;

Specimen thickness: 1-11mm.

### Grip specification

Model	Max load	Temp.	Size(H*W*D)(mm)
JJ.021-105-A.D3410	100kN	RT	214×135×174
JJ.022-105-A.D3410	100kN	-70~350°C	214×135×174

## Combined Loading Compression (CLC) Fixture

This fixture is suitable for in-plane compression performance testing of fiber-reinforced plastics. It can meet the requirements of ASTM D6641. The fixture is simple to install and easy to operate.

### Application

1. Specimen thickness: 12.7mm;
2. Specimen width: 13mm.

### Grip specification

Model	Max load	Temp.	Size(H*W*D)(mm)
JJ.021-105-A.D6641	100kN	RT	141×105×55
JJ.022-105-A.D6641	100kN	-70~350°C	141×105×55



## Beam Bending and Shear Test Fixture

This set of fixtures is designed according to ASTM C393, and the relevant size of the fixture can be determined according to customer needs. This fixture includes four-point bending and three-point bending test methods. (The support roller structure is a four-point bending structure).

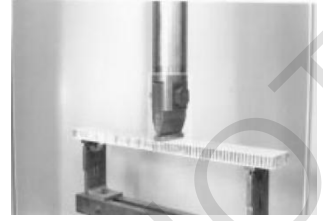

### Application

1. Upper span: Max. 450mm;
2. Lower span: Max. 600mm;
3. Specimen thickness: 0~30mm.

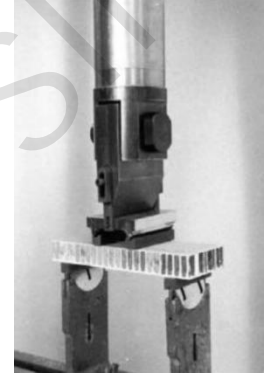
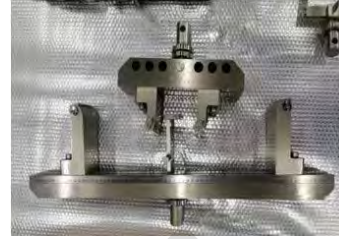

### Grip specification

Model	Max. load	Temp.	Size(H*W*D)(mm)
JJ.021-104-A.C393	10kN	RT	400×720×100
JJ.022-104-A.C393	10kN	-70~350°C	400×720×100

## Three Point Bending Fixture

This fixture is suitable for surface bending performance testing of fiber-reinforced plastics, which complies with relevant requirements of ASTM D7905. The fixture is simple to install and easy to operate.



### Application

1. Max. Span: 200mm;
2. Diameter of support roller:  $\phi 10\text{mm}$ .

### Grip specification

Model	Max load	Temp.	Size(H*W*D)(mm)
JJ.021-105-A.D7905	50kN	RT	282×300×72
JJ.022-105-A.D7905	50kN	-70~350°C	282×300×72

## Three Point/ Four Point Bending Fixture

This fixture is suitable for surface bending performance testing of fiber-reinforced plastics. Meets the relevant requirements of ASTM D7264. The fixture is simple to install and easy to operate.



### Application

1. Max. upper span: 150mm;
2. Max. lower span: 200mm;
3. Diameter of supporting roller:  $\phi 10$ mm.

### Grip specification

Model	Max. load	Temp.	Size(H*W*D)(mm)
JJ.021-105-A.D7264	50kN	RT	300×300×75
JJ.022-105-A.D7264	50kN	-70~350℃	300×300×75

## Short Beam Bending Fixture

This fixture is suitable for surface bending performance testing of fiber-reinforced plastics. Comply with relevant requirements of ASTM D2344. The fixture is simple to install and easy to operate.



### Application

1. Max. span: 200mm;
2. Diameter of supporting roller:  $\phi 3$ mm.

### Grip specification

Model	Max. load	Temp.	Size(H*W*D)(mm)
JJ.021-105-A.D2344	50kN	RT	210×350×80
JJ.022-105-A.D2344	50kN	-70~350°C	210×350×80

## Fastener Bearing Strength Test Fixtures

This fixture is suitable for surface compression and shear performance testing of fiber-reinforced plastics. Meets the relevant requirements of ASTM D5961PB. The fixture is simple to install and easy to operate.

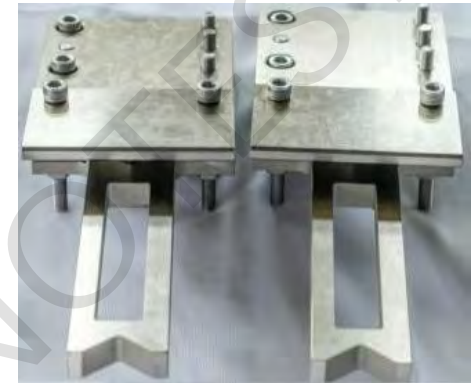

### Grip specification

Model	Max. load	Temp.	Size(H*W*D)(mm)
JJ.021-305-A.D5961B	250kN	RT	340×80×56
JJ.022-305-A.D5961B	250kN	-70~350°C	340×80×56

## Open-Hole Compression Fixture

This fixture is suitable for surface compression and shear performance testing of fiber-reinforced plastics. Meets the relevant requirements of ASTM D6484. The fixture is simple to install and easy to operate.

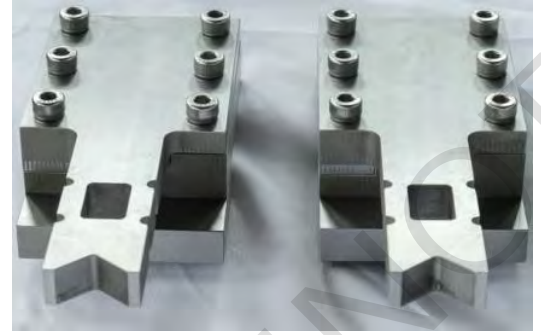

### Grip specification

Model	Max. load	Temp.	Size(H*W*D)(mm)
JJ.021-305-A.D6484	250kN	RT	305×80×58
JJ.022-305-A.D6484	250kN	-70~350°C	305×80×58

## Sandwich Core Compression and Shear Fixture

This fixture is designed according to ASTM C273 standard and is suitable for testing the compression and shear properties of sandwich structures or cores.



### Application

1. Specimen thickness: 20mm;
2. Specimen length: ≤250mm;
3. Specimen width: ≤50mm.

### Grip specification

Model	Max. load	Temp.	Size(H*W*D)(mm)
JJ.021-105-A.C273B	50kN	RT	480×94×52
JJ.022-105-A.C273B	50kN	-70~350°C	480×94×52



## Sandwich Core Tensile and Shear Fixture

This fixture is designed according to ASTM C273 standard and is suitable for testing the tensile and shear properties of sandwich structures or cores.

### Application

1. Specimen thickness: 5~20mm;
2. Specimen length:  $\leq 250$ mm;
3. Specimen width:  $\leq 50$ mm.



### Grip specification

Model	Max. load	Temp.	Size(H*W*D)(mm)
JJ.021-105-A.C273A	50kN	RT	520×90×80
JJ.022-105-A.C273A	50kN	-70~350℃	520×90×80

## Climbing Drum Peel Test Fixture

This fixture is designed according to ASTM D1781 (Standard Test Method for Climbing Drum Peel for Adhesives) and is used to determine the peel strength of the adhesive bond between the panel and core in a sandwich structure.

### Application

1. Specimen width:  $\leq 80\text{mm}$ ;

### Grip specification

Model	Max. load	Temp.	Size(H*W*D)(mm)
JJ.021-204-A.D1781	1kN	RT	450×200×200
JJ.022-204-A.D1781	1kN	-70~350°C	450×200×200

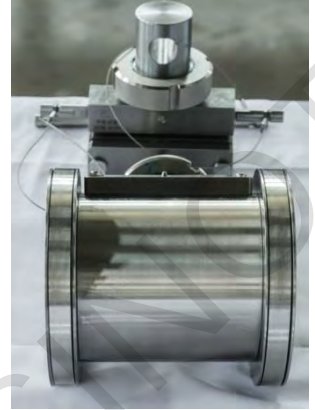

## Mixed-Mode Bending Fracture Toughness Test Fixture

This fixture is suitable for interlaminar fracture toughness testing. Meets the relevant requirements of ASTM D6671. The fixture is simple to install and easy to operate. It needs to be used together with the lower compression platen.

### Grip specification

Model	Max. load	Temp.	Size(H*W*D)(mm)
JJ.021-204-A.D6671	10kN	RT	252×254×110
JJ.022-204-A.D6671	10kN	-70~350°C	252×254×110

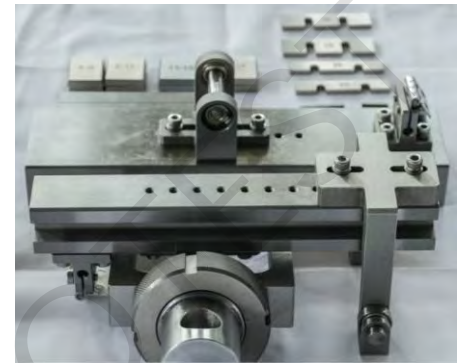

## Roller Drum Peel Test Fixture

This fixture is suitable for floating roller peeling test and complies with the relevant requirements of ASTM D3167.

### Application

1. Max. Specimen width: 30mm。

### Grip specification

Model	Max. load	Temp.	Size(H*W*D)(mm)
JJ.021-204-A.D3167	10kN	RT	280×98×80
JJ.022-204-A.D3167	10kN	-70~350°C	280×98×80



## Glass Fiber Special Shearing Fixture

This fixture is suitable for shear testing of glass fibers and complies with the ASTM D7078/D 7078M-05 standard.

### Grip specification

Model	Max. load	Temp.	Size(H*W*D)(mm)
JJ.021-105-A.D7078	100kN	RT	285×106×100
JJ.022-105-A.D7078	100kN	-70~350°C	285×106×100



## V-Notched Rail Shear Test Fixture

This fixture is suitable for V-notch shear testing of composite materials and complies with ASTM D5379/D5379M-05 standard requirements. The fixture must be used with a standard  $\phi 150\text{mm}$  compression platen.



### Grip specification

Model	Max. load	Temp.	Size(H*W*D)(mm)
JJ.021-105-A.D5379	50kN	RT	205×160×80
JJ.022-105-A.D5379	50kN	-70~350°C	205×160×80

## Mode I Interlaminar Fracture Toughness Test Fixture

This fixture is suitable for interlaminar fracture toughness testing. Comply with relevant requirements of ASTM D5528. The fixture is simple to install and easy to operate.



### Grip specification

Model	Max. load	Temp.	Size(H*W*D)(mm)
JJ.021-204-A.D5528	10kN	RT	265×220×75
JJ.022-204-A.D5528	10kN	-70~350°C	265×220×75